

MP-V

SmartX IP Controller



Introduction

SmartX IP Controller – MP-V is a multi-purpose, fully programmable, IP based field controller dedicated for VAV cooling and heating applications. MP-V integrates a controller, a damper actuator, and an air flow sensor in a single compact package for ease of installation. MP-V can either be used as a standalone BACnet/IP field controller or as part of an EcoStruxure BMS with a SmartX AS-P or AS-B server or an Enterprise Server as the parent server. MP-V comes in two models with different I/O count.

The MP-V has the following features:

- IP enabled with dual port Ethernet switch
- Integrated damper actuator with feedback signal
- Factory-calibrated air flow sensor
- High reliability
- Sensor bus for living space sensors
- Mobile commissioning application
- Full EcoStruxure Building Operation software support, providing efficient engineering tools

IP connectivity and flexible network topologies

The MP Series controllers are based on open protocols that simplify interoperability, IP configuration, and device management:

- IP addressing
- BACnet/IP communications
- DHCP for easy network configuration

The MP Series controllers have a dual-port Ethernet switch, which enables flexible network topologies:

- Star
- Daisy chain
- Rapid Spanning Tree Protocol (RSTP) ring

In a star topology, the controller and the parent EcoStruxure BMS server are individually connected to an Ethernet switch. You can reduce the installation time and cost by daisy-chaining multiple controllers together. You can use an RSTP ring topology when you want failures of a single controller to be detected and recovered quickly and efficiently.

Models with a versatile mix of I/O points

MP-V comes in two models with different I/O point count and a versatile mix of I/O point types that match a wide variety of VAV applications.

MP-V

SmartX IP Controller

I/O Point Types by MP-V Models

I/O Point Types	MP-V-7A	MP-V-9A
Universal inputs	3	4
Triac outputs	3	3
Analog outputs	1	2

Configurations by I/O Point Types

Configurations	Universal Inputs	Triac Outputs	Analog Outputs
Digital inputs	yes	-	-
Counter inputs	yes	-	-
Supervised inputs	yes	-	-
Voltage inputs (0 to 10 VDC)	yes	-	-
Current inputs (0 to 20 mA)	yes	-	-
Temperature inputs	yes	-	-
Resistive inputs	yes	-	-
2-wire RTD temperature inputs	yes	-	-
Digital outputs	-	yes	-
Digital pulsed outputs	-	yes	-
PWM outputs	-	yes	-
Tristate outputs	-	yes	-
Tristate pulsed outputs	-	yes	-
Voltage outputs (0 to 10 VDC)	-	-	yes
Current outputs (0 to 20 mA)	-	-	yes

Universal inputs

The universal inputs are ideal for any mix of temperature, pressure, flow, status points, and similar point types in a building control system.

As counter inputs, they are commonly used in energy metering applications. As RTD inputs, they are ideal for temperature points in a building control system. As supervised inputs, they are used for security applications where it is critical to know whether or not a wire has been cut or shorted. These events provide a separate indication of alarms and trouble conditions to the system.

For all analog inputs, maximum and minimum levels can be defined to automatically detect over-range and under-range values.

Triac outputs

The triac outputs can be used in many applications to switch 24 VAC on or off for external loads such as actuators, relays, or indicators. The triac outputs are isolated from the controller. Triacs are silent and do not suffer from relay contact wear.

MP-V

SmartX IP Controller

Analog outputs

The analog outputs are capable of supporting analog voltage or current point types, without the need for external bias resistors. Therefore, analog outputs support a wide range of devices, such as actuators.

Integrated damper actuator with feedback signal

The integrated damper actuator allows for simplified installation of MP-V directly over the damper shaft. This eliminates the need for separate installation, wiring, and positioning of the damper motor. MP-V uses the same actuator mechanics as many Schneider Electric VAV controller models from the Andover Continuum, TAC Vista, TAC I/A Series, and TAC I/NET product lines. The feedback signal from the actuator makes it possible to determine the exact position of the damper. The actuator also features a push button for manual positioning of the damper during commissioning.

Factory-calibrated air flow sensor

The factory-calibrated air flow sensor uses a state-of-the-art technology that requires no air flow from the velocity probe. Unlike flow-through sensors, the sensor does not impose rigid requirements on tubing, dust, or filters, and the sensor is not affected by errors induced on the local probe pressure readings. The sensor requires no maintenance and a minimum of field adjustments.

High reliability

The MP Series controllers support local trends, schedules, and alarms, enabling local operation when the controller is offline or used in standalone applications.

The battery-free power backup of the memory and real-time clock prevents data loss and ensures seamless and quick recovery after a power failure.

WorkStation allows you to update the firmware of multiple MP Series controllers at the same time and with minimum down time. The EcoStruxure BMS server keeps track of the installed firmware to support backup, restore, and replacement of the controllers and sensors. The server can host controllers of different firmware versions.

Sensor bus for living space sensors

The MP Series controllers provide an interface designed for the SmartX Sensor family of living space sensors. The SmartX Sensors offer an efficient way to sense the temperature, humidity, CO₂, and occupancy

in a room. The SmartX Sensors are available with different combinations of sensor types and various covers and user interface options, such as touchscreen, setpoint and override buttons, and blank covers.



SmartX Sensors

The sensor bus provides both power and communications for up to four sensors that are daisy-chained using standard Cat 5 (or higher) cables. The maximum number of sensors that can be connected to a controller varies depending on the sensor model and the combination of cover and sensor base type:

- Blank covers: Up to four sensors of any combination of sensor base types
- 3-button and touchscreen covers:
 - Up to two sensor bases with CO₂ option
 - Up to four sensor bases without CO₂ option
- SmartX LCD temperature sensors: Up to four sensors are supported

The maximum total length of the sensor bus is 61 m (200 ft). For more information, see the SmartX Living Space Sensors Specification Sheet.

Mobile commissioning application

The eCommission SmartX Controllers mobile application is designed for local configuration, field deployment, and commissioning of MP Series controllers, and air flow balancing of VAV units. The mobile application reduces the commissioning time, allows flexibility in project execution, and eliminates dependencies on network infrastructure.

The mobile application is designed for use with Android, Apple (iOS), and Microsoft Windows 10 devices. For more information, see the eCommission SmartX Controllers Specification Sheet.

MP-V

SmartX IP Controller

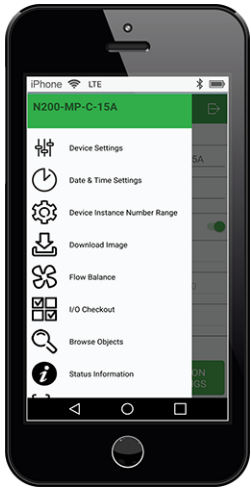

eCommission SmartX Controllers mobile app

Using the eCommission SmartX Controllers mobile application, you can connect to one or many MP Series controllers. You can connect to a single MP Series controller using the eCommission Bluetooth Adapter connected to a SmartX Sensor. You can connect to a network of MP Series controllers on the local IP network, using a wireless access point or a network switch.

Device configuration

With the eCommission SmartX Controllers mobile application, you can easily discover MP Series controllers on the IP network and change each controller's configuration, including the BACnet and IP network settings, location, and parent server. To save engineering time, you can save common device settings and then reuse them for controllers of the same model.

Field deployment and I/O checkout

The eCommission SmartX Controllers mobile application does not require an EcoStruxure BMS server or a network infrastructure to be in place. You can use the mobile application to load the controller application directly into the local MP Series controller and deploy the controller. The controller application can be created offline using Project Configuration Tool or WorkStation. You can also perform an I/O checkout to ensure that the controller's I/O points are configured, wired, and operating correctly.

Air flow balancing

Using the eCommission SmartX Controllers mobile application, you can perform air flow balancing of VAV units controlled by MP-Vs. An intuitive workflow automatically guides you through the process. After the

flow balancing, you can generate a report in HTML format for one or more VAV units. The balancing parameters associated with each MP-V are stored in the parent server, which makes it easier to replace the controller if necessary.

Full EcoStruxure Building Operation software support

The power of the MP Series controller is fully realized when it is part of an EcoStruxure BMS, which provides the following benefits:

- WorkStation/WebStation interface
- Script and Function Block programming options
- Device discovery
- Engineering efficiency

WorkStation/WebStation interface

WorkStation and WebStation provide a consistent user experience regardless of which EcoStruxure BMS server the user is logged on to. The user can log on to the parent EcoStruxure BMS server to engineer, commission, supervise, and monitor the MP Series controller and its I/O as well as its attached SmartX Sensors. For more information, see the WorkStation and WebStation specification sheets.

Script and Function Block programming options

Unique to the industry, the MP Series controllers have both Script and Function Block programming options. This flexibility assures that the best programming method can be selected for the application. Existing programs can easily be reused between the EcoStruxure BMS server and the controller.

Device discovery

The enhanced Device Discovery in WorkStation enables you to easily identify MP Series controllers on a BACnet network and to associate the controllers with their parent server.

Engineering efficiency

The engineering and maintenance of MP Series controllers can be done very efficiently using the EcoStruxure Building Operation reusability features. With these features, you can create library items (Custom Types) for a complete controller application that contains programs and all necessary objects such as trends, alarms, and schedules. The controller application in the Custom Types library is reusable across all controllers of the same model. You can use the controller application as a base for creating new

MP-V

SmartX IP Controller

controllers intended for similar applications. You can then edit the controller application, and the changes are automatically replicated to all controllers, while each controller keeps its local values.

WorkStation supports both online and offline engineering of MP Series controllers. You can make the configuration changes online or use database mode to make the changes offline. In database mode, the changes are saved to the EcoStruxure Building Operation database so that you can apply the changes to the controllers later.

Project Configuration Tool enables you to perform all the engineering off site, without the need for physical hardware, which minimizes the time you need to spend on site. You can run the EcoStruxure BMS servers virtually and engineer the MP Series controllers, before you deploy your server and controller applications to the servers and controllers on site. For more information, see the Project Configuration Tool specification sheet.

In addition, you can use Automated Engineering Tool to facilitate your engineering process when using MP Series controllers. This tool provides access to a library of standard controller applications. These standard applications can be quickly configured and customized

using the wizards and mass edit functions provided in the tool and then loaded into your target server. The tool also enables the quick creation of your own templates based on MP Series controller applications that you have developed. This facilitates a standard approach and drives the ability to easily reuse and duplicate common controller applications. For more information, see the Automated Engineering Tool specification sheet.

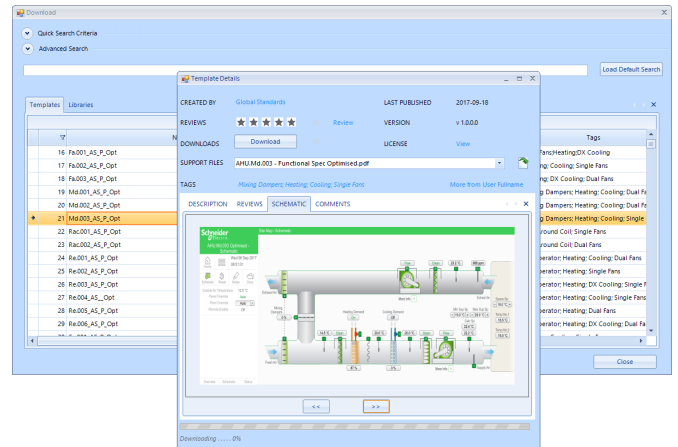

Library of standard HVAC applications

Part Numbers

Product	Part number
MP-V-7A	SXWMPV7AX10001
MP-V-9A	SXWMPV9AX10001
Spare terminal blocks for all MP-V models (1 x 2-pin, 2 x 3-pin, 2 x 4-pin, 1 x 5-pin, 1 x 6-pin terminal blocks)	SXWMPVCON10001
Adapter for damper shaft diameter 9.5 mm (0.375 inch)	AM-135
eCommission Bluetooth Adapter	SXWBTAECXX10001

Specifications

AC input

Nominal voltage	24 VAC
Operating voltage range	+/-20 %
Frequency	50/60 Hz
Maximum power consumption (MP-V-7A)	21 VA
Maximum power consumption (MP-V-9A)	22 VA
Power input protection	MOV suppression and internal fuse

MP-V

SmartX IP Controller

Environment

Ambient temperature, operating0 to 50 °C (32 to 122 °F)
 Ambient temperature, storage-40 to +70 °C (-40 to +158 °F)
 Maximum humidity.....95 % RH non-condensing

Material

Plastic flame ratingUL94 V-0
 Ingress protection ratingIP 20

Mechanical

Dimensions161 W x 198 H x 63 D mm (6.3 W x 7.8 H x 2.5 D in.)

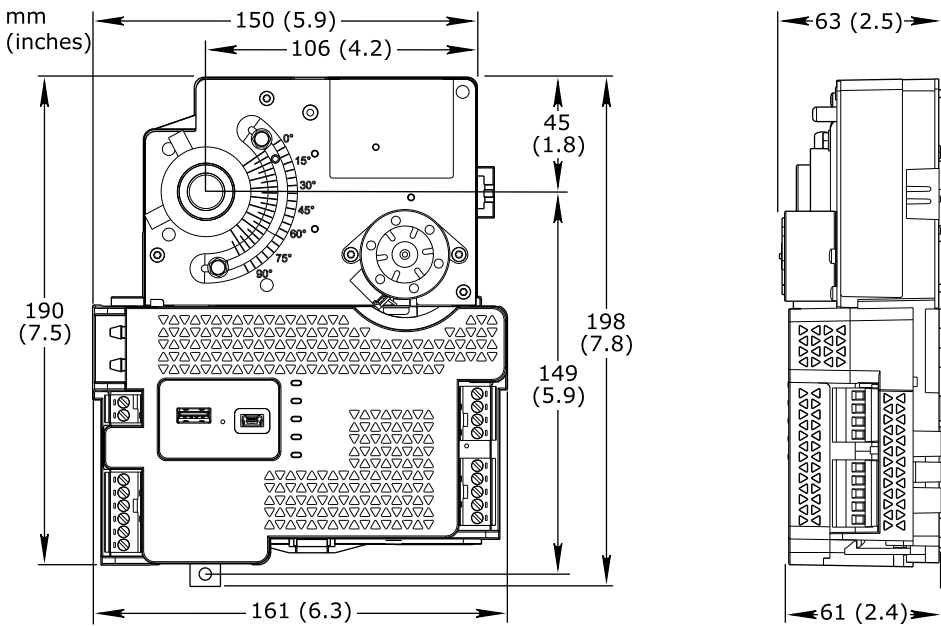

Weight1.13 kg (2.5 lb)
 InstallationOver the damper shaft
 Terminal blocksRemovable

Software compliance

EcoStruxure Building Operation softwareversion 2.0 or later

Agency compliances

EmissionRCM; EN 61000-6-3; EN 50491-5-2; FCC Part 15, Sub-part B, Class B
 ImmunityEN 61000-6-2; EN 50491-5-3
 SafetyEN 60730-1; EN 60730-2-11; EN 50491-3; UL 916 C-UL US Listed
 Fire performance in air-handling spaces^a UL 2043
 a) MP-V-7A and MP-V-9A are approved for plenum applications.

Real-time clock

Accuracy, at 25 °C (77 °F) +/-1 minute per month
 Backup time, at 25 °C (77 °F)7 days minimum

MP-V

SmartX IP Controller

Communication ports

Ethernet	Dual 10/100BASE-TX (RJ45)
USB	USB 2.0, 5 VDC, 2.5 W, 1 device port (mini-B) and 1 host port (type-A)
Sensor Bus	24 VDC, 2 W, RS-485 (RJ45)
Sensor Bus protection	Transient voltage suppressors on communication and power signals

Communications

BACnet	BACnet/IP, port configurable, default 47808 BTL B-AAC (BACnet Advanced Application Controller) ^a
a) See the BTL Product Catalog for up-to-date details on BTL listed firmware revisions on BACnet International's home page.	

CPU

Frequency	500 MHz
Type	ARM Cortex-A7 dual-core
DDR3 SDRAM	128 MB
NOR flash memory	32 MB
Memory backup	128 kB, FRAM, non-volatile

Damper actuator

Torque rating	6 Nm (53 lbf.in)
Stroke	0° to 90°, fully adjustable
Timing	Approximately 2 seconds/degree at 60 Hz and 2.4 seconds/degree at 50 Hz for 90° rotation at 24 VAC
Position indication	Visual indication
Damper position feedback	Yes
Manual override	Push-button clutch release
Damper shaft diameter	12.7 mm (0.5 inch) or 9.5 mm (0.375 inch) Adapter kit AM-135 is required for 9.5 mm (0.375 inch) diameter shafts.
Damper shaft minimum length (from VAV box)	22.2 mm (0.875 inch)

Air flow sensor

Range	0 to 249 Pa (0 to 1 inH ₂ O)
Resolution	0.33 Pa (0.001 inH ₂ O) at 25°C (77°F)
Accuracy	±5% of 249 Pa (1.00 inH ₂ O) span at 25°C (77°F)

Universal inputs, UI

Channels, MP-V-7A	3, UI1–UI3
Channels, MP-V-9A	4, UI1–UI4
Absolute maximum ratings	-0.5 to +24 VDC
A/D converter resolution	16 bits
Universal input protection	Transient voltage suppressor on each input

Digital inputs

Range	Dry contact switch closure or open collector/open drain, 24 VDC, typical wetting current 2.4 mA
Minimum pulse width	150 ms

MP-V

SmartX IP Controller

Counter inputs

Range	Dry contact switch closure or open collector/open drain, 24 VDC, typical wetting current 2.4 mA
Minimum pulse width	20 ms
Maximum frequency	25 Hz

Supervised inputs

5 V circuit, 1 or 2 resistors	
Monitored switch combinations	Series only, parallel only, and series and parallel
Resistor range	1 to 10 kohm
For a 2-resistor configuration, each resistor must have the same value +/- 5 %	

Voltage inputs

Range	0 to 10 VDC
Accuracy	+/- (7 mV + 0.2 % of reading)
Resolution	1.0 mV
Impedance	100 kohm

Current inputs

Range	0 to 20 mA
Accuracy	+/- (0.01 mA + 0.4 % of reading)
Resolution	1 µA
Impedance	47 ohm

Resistive inputs

10 ohm to 10 kohm accuracy	+/- (7 + 4 x 10 ⁻³ x R) ohm
R = Resistance in ohm	
10 kohm to 60 kohm accuracy	+/- (4 x 10 ⁻³ x R + 7 x 10 ⁻⁸ x R ²) ohm
R = Resistance in ohm	

Temperature inputs (thermistors)

Range	-50 to +150 °C (-58 to +302 °F)
-------------	---------------------------------

Supported thermistors

Honeywell	20 kohm
Type I (Continuum)	10 kohm
Type II (I/NET)	10 kohm
Type III (Satchwell)	10 kohm
Type IV (FD)	10 kohm
Type V (FD w/ 11k shunt)	Linearized 10 kohm
Satchwell D?T	Linearized 10 kohm
Johnson Controls	2.2 kohm
Xenta	1.8 kohm
Balco	1 kohm

Measurement accuracy

20 kohm	-50 to -30 °C: +/- 1.5 °C (-58 to -22 °F: +/- 2.7 °F)
---------------	---

MP-V

SmartX IP Controller

.....	-30 to 0 °C: +/-0.5 °C (-22 to +32 °F: +/-0.9 °F)
.....	0 to 100 °C: +/-0.2 °C (32 to 212 °F: +/-0.4 °F)
.....	100 to 150 °C: +/-0.5 °C (212 to 302 °F: +/-0.9 °F)
10 kohm, 2.2 kohm, and 1.8 kohm.....	-50 to -30 °C: +/-0.75 °C (-58 to -22 °F: +/-1.35 °F)
.....	-30 to +100 °C: +/-0.2 °C (-22 to +212 °F: +/-0.4 °F)
.....	100 to 150 °C: +/-0.5 °C (212 to 302 °F: +/-0.9 °F)
Linearized 10 kohm	-50 to -30 °C: +/-2.0 °C (-58 to -22 °F: +/-3.6 °F)
.....	-30 to 0 °C: +/-0.75 °C (-22 to +32 °F: +/-1.35 °F)
.....	0 to 100 °C: +/-0.2 °C (32 to 212 °F: +/-0.4 °F)
.....	100 to 150 °C: +/-0.5 °C (212 to 302 °F: +/-0.9 °F)
1 kohm	-50 to +150 °C: +/-1.0 °C (-58 to +302 °F: +/-1.8 °F)

RTD temperature inputs

Supported RTDs.....Pt1000

Pt1000

Range.....-50 to +150 °C (-58 to +302 °F)

Measurement accuracy-50 to +70 °C: +/-0.5 °C (-58 to +158 °F: +/-0.9 °F)

.....70 to 150 °C: +/-0.7 °C (158 to 302 °F: +/-1.3 °F)

RTD temperature wiring

Maximum wire resistance.....20 ohm/wire (40 ohm total)

Maximum wire capacitance.....60 nF

The wire resistance and capacitance typically corresponds to a 200 m wire.

Triac outputs, DO

Channels, MP-V-7A 3, DO1–DO3

Channels, MP-V-9A 3, DO1–DO3

Output rating (for each triac output)Max. 0.5 A

Voltage.....24 VAC +/-20 %

Commons.....COM (terminal number 18)

The common terminal COM can be connected to 24 VAC or to ground.

Common voltage, high side output.....24 VAC

Common voltage, low side output0 VAC (ground)

Minimum pulse width100 ms

Triac output protectionMOV and snubber across each triac output

.....MOV from triac COM to ground

Analog outputs, AO

Channels, MP-V-7A 1, VO1/CO1

Channels, MP-V-9A2, VO1/CO1 and VO2/CO2

Analog output protectionTransient voltage suppressor on each output

Voltage outputs

Range.....0 to 10 VDC

Accuracy.....+/-60 mV

Resolution.....10 mV

MP-V

SmartX IP Controller

Minimum load resistance.....5 kohm to ground
 Load range.....0 to +2 mA
 TerminalsVoltage Output (VO), Return (RET)

Current outputs

Range.....0 to 20 mA
 Accuracy+/-0.2 mA
 Resolution.....21 µA
 Load range.....0 to 650 ohm
 TerminalsCurrent Output (CO), Return (RET)

Terminals

Be sure to follow proper installation wiring diagrams and instructions, including these instructions:

- MP-V-7A and MP-V-9A have several RET terminals for connection of I/O returns, so a common chassis/signal ground rail is optional and may not be needed.
- Individual 24 VDC power sources to the field must be current limited to maximum 4 A for UL compliant installations, and maximum 6 A in other areas.
- For more information on wiring, see Hardware Reference Guide.

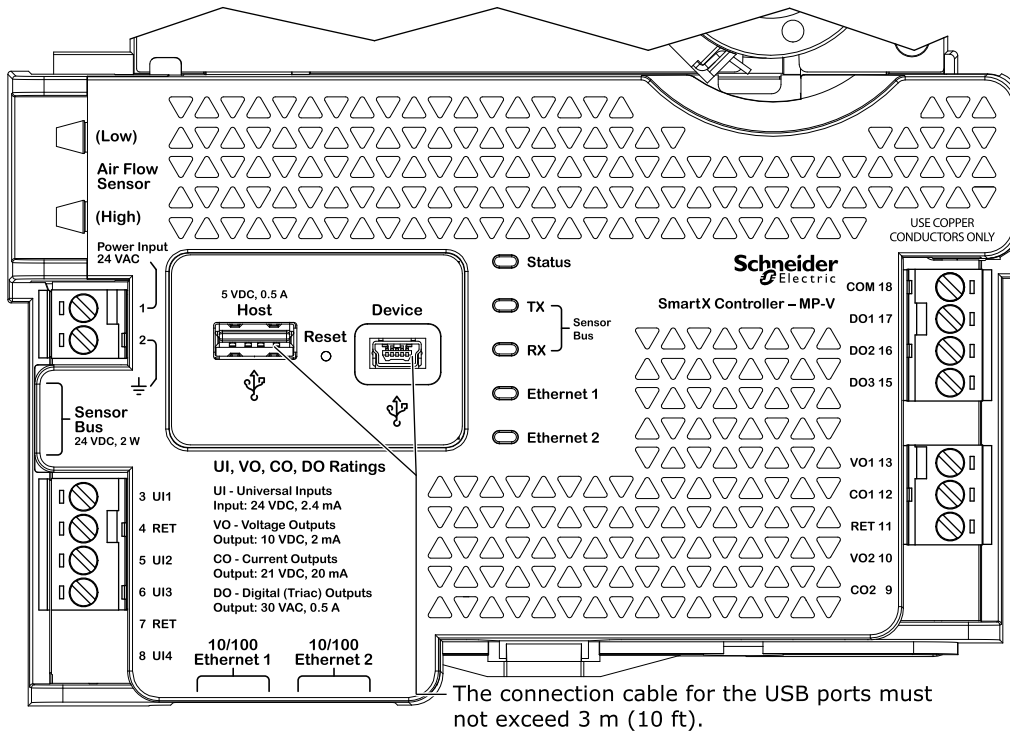

MP-V-7A

MP-V

SmartX IP Controller

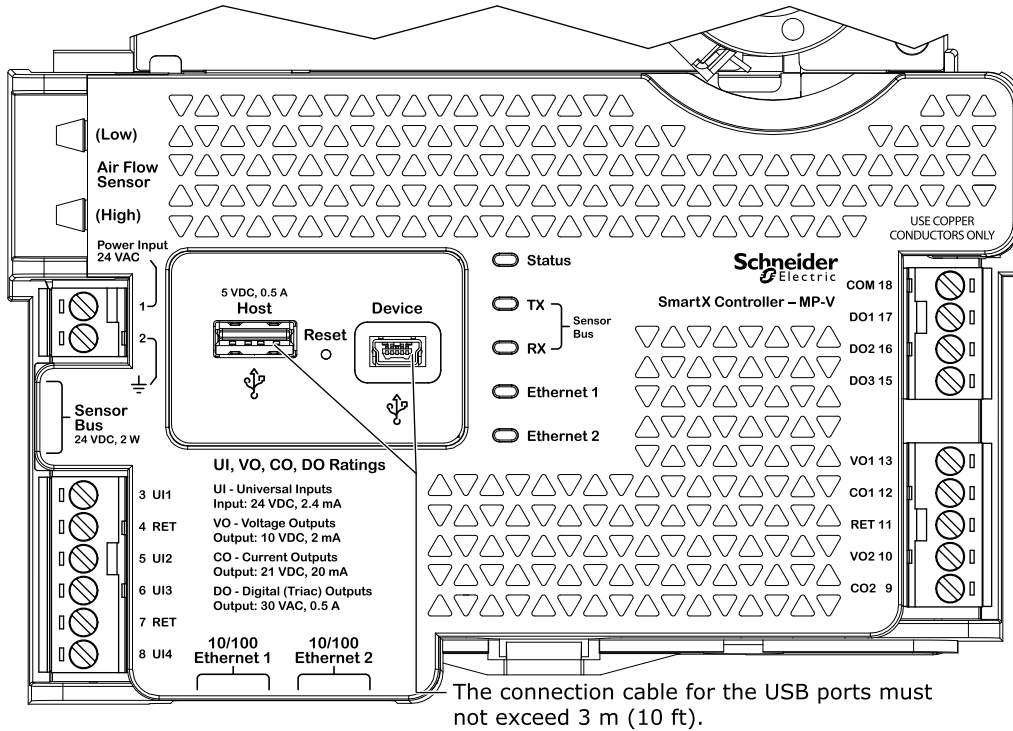

MP-V-9A

Part Numbers in AMER Region for Network Connectivity Accessories

Product description ^a	Part number (AMER region)
Cat 6 field-term plug, UTP	ACTPG6TLU001
Cat 6 pass-through plug, UTP, 100-pack	ACTPG6PTU100
Actassi crimping tool	ACTTLCPT
Cat 6 cable, UTP, 1000 ft (305 m), CMP, green	ACT4P6UCP1ARXGR
Cat 6 patch cord, UTP, 30 ft (9 m), CMP, green	ACTPC6UBCP30AGR
Cat 6 patch cord, UTP, 50 ft (15 m), CMP, green	ACTPC6UBCP50AGR
Cat 6 patch cord, UTP, 70 ft (21 m), CMP, green	ACTPC6UBCP70AGR
Cat 6 patch cord, UTP, 90 ft (27 m), CMP, green	ACTPC6UBCP90AGR
Cat 5e pass-through plug, UTP, 100-pack	ACTPG5EPTU100
Cat 5e cable, UTP, 1000 ft (305 m), CMP, green	ACT4P5EUCP1ARXGR
Cat 5e patch cord, UTP, 30 ft (9 m), CMP, green	ACTPC5EUBCP30AGR
Cat 5e patch cord, UTP, 50 ft (15 m), CMP, green	ACTPC5EUBCP50AGR
Cat 5e patch cord, UTP, 70 ft (21 m), CMP, green	ACTPC5EUBCP70AGR
Cat 5e patch cord, UTP, 90 ft (27 m), CMP, green	ACTPC5EUBCP90AGR

a) For more information, see the Product Selection Guide (SmartX IP Controllers - Accessories). Abbreviations: UTP (Unshielded Twisted Pair), CMP (Plenum-rated cable)

MP-V

SmartX IP Controller

Part Numbers in EMEA Region for Network Connectivity Accessories

Product description ^a	Part number (EMEA region)
Cat 6 field-term plug, UTP	ACTPG6TLU001
Cat 6 pass-through plug, UTP, 100-pack	ACTPG6PTU100
Actassi crimping tool	ACTTLCPT
Cat 6 cable, UTP, 305 m (1000 ft), Euroclass D, green	VDICD116118
Cat 6 patch cord, UTP, 10 m (32 ft), LSZH, green	ACTPC6UBLS100GR
Cat 6 patch cord, UTP, 15 m (49 ft), LSZH, green	ACTPC6UBLS150GR
Cat 6 patch cord, UTP, 20 m (65 ft), LSZH, green	ACTPC6UBLS200GR
Cat 6 patch cord, UTP, 25 m (82 ft), LSZH, green	ACTPC6UBLS250GR
Cat 5e pass-through plug, UTP, 100-pack	ACTPG5EPTU100
Cat 5e cable, UTP, 1000 ft (305 m), Euroclass D, green	VDICD115118
Cat 5e patch cord, UTP, 10 m (32 ft), LSZH, green	ACTPC5EUBLS100GR
Cat 5e patch cord, UTP, 15 m (49 ft), LSZH, green	ACTPC5EUBLS150GR
Cat 5e patch cord, UTP, 20 m (65 ft), LSZH, green	ACTPC5EUBLS200GR
Cat 5e patch cord, UTP, 25 m (82 ft), LSZH, green	ACTPC5EUBLS250GR

a) For more information, see the Product Selection Guide (SmartX IP Controllers - Accessories). Abbreviations: UTP (Unshielded Twisted Pair), CMP (Plenum-rated cable), LSZH (Low Smoke Zero Halogen)

Part Numbers in Pacific Region for Network Connectivity Accessories

Product description ^a	Part number (Pacific region)
Cat 6 field-term plug, UTP	ACTPG6TLU001
Cat 6 pass-through plug, UTP, 100-pack	ACTPG6PTU100
Actassi crimping tool	ACTTLCPT
Cat 6 cable, UTP, 305 m (1000 ft), PVC, green	2D4P6IPV3B-GR
Cat 6 patch lead, UTP, 10 m (32 ft), PVC, green	RJ6_100PL-GR
Cat 6 patch lead, UTP, 15 m (49 ft), PVC, green	RJ6_150PL-GR
Cat 6 patch lead, UTP, 20 m (65 ft), PVC, green	RJ6_200PL-GR
Cat 6 patch lead, UTP, 25 m (82 ft), PVC, green	RJ6_250PL-GR
Cat 5e pass-through plug, UTP, 100-pack	ACTPG5EPTU100
Cat 5e cable, UTP, 305 m (1000 ft), PVC, green	2D4P5IPV3B-GR
Cat 5e patch lead, UTP, 10 m (32 ft), PVC, green	RJ5_100PL-GR
Cat 5e patch lead, UTP, 15 m (49 ft), PVC, green	RJ5_150PL-GR
Cat 5e patch lead, UTP, 20 m (65 ft), PVC, green	RJ5_200PL-GR
Cat 5e patch lead, UTP, 25 m (82 ft), PVC, green	RJ5_250PL-GR

a) For more information, see the Product Selection Guide (SmartX IP Controllers - Accessories). Abbreviations: UTP (Unshielded Twisted Pair), PVC (Polyvinyl chloride)

MP-V

SmartX IP Controller

Regulatory Notices

FC Federal Communications Commission

FCC Rules and Regulations CFR 47, Part 15, Class B

This device complies with part 15 of the FCC Rules. Operation is subject to the following two conditions: (1) This device may not cause harmful interference. (2) This device must accept any interference received, including interference that may cause undesired operation.

Industry Canada

This Class B digital apparatus complies with Canadian ICES-003.

Cet appareil numérique de la classe B est conforme à la norme NMB-003 du Canada.

Regulatory Compliance Mark (RCM) - Australian Communications and Media Authority (ACMA)

This equipment complies with the requirements of the relevant ACMA standards made under the Radiocommunications Act 1992 and the Telecommunications Act 1997. These standards are referenced in notices made under section 182 of the Radiocommunications Act and 407 of the Telecommunications Act.

CE - Compliance to European Union (EU)

2014/30/EU Electromagnetic Compatibility Directive

2011/65/EU Restriction of Hazardous Substances (RoHS) Directive

This equipment complies with the rules, of the Official Journal of the European Union, for governing the Self Declaration of the CE Marking for the European Union as specified in the above directive(s) per the provisions of the following standards: EN 60730-1, EN 60730-2-11, and EN 50491-3 Safety Standards.



WEEE - Directive of the European Union (EU)

This equipment and its packaging carry the waste of electrical and electronic equipment (WEEE) label, in compliance with European Union (EU) Directive 2012/19/EU, governing the disposal and recycling of electrical and electronic equipment in the European community.



UL 916 Listed products for the United States and Canada, Enclosed Energy Management Equipment. UL file E80146.